

stern

STERN ENGINEERING LTD.



ELECTRONIC FLUSH VALVES

VENUS 3002 SERIES

JUPITER 3002 SERIES

INSTALLATION AND MAINTENANCE GUIDE

INDEX

1	TECHNICAL DATA
2-3	PACK CONTENTS
4	PRE-INSTALLATION INFO
5-6	INSTALLATION
7-9	MANUAL RANGE ADJUSTMENTS
10-11	SETTINGS ADJUSTMENT
11-13	BATTERY REPLACEMENT
14	MAINTENANCE
15	SPARE PARTS LIST
16	SERVICE CHECK LIST
17	WARRANTY

TECHNICAL DATA

Power supply	Internally mounted 9V battery or 9V transformer
Recommended water pressure	1.0-8.0 bar (14.5-116 PSI) With water pressure of more than 8 bars, use a pressure reducing valve for reduction.
Jupiter sensor range	600 +-20 MM
Venus sensor range	650 +-50 MM
24 hour automatic flush	Maintains trap seal every 24 hours when not used.
Prior use flush mode	Optional feature at specific models

TECHNICAL DATA

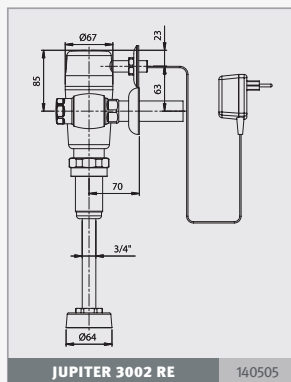
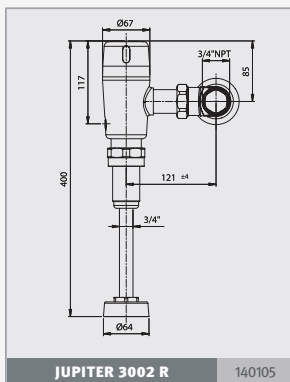
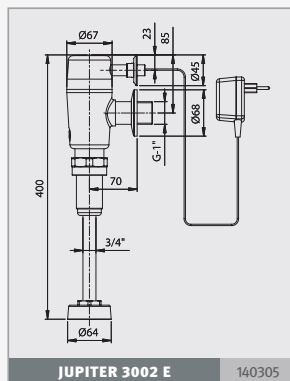
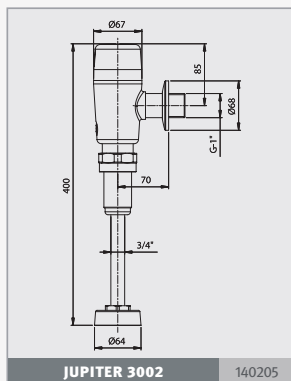
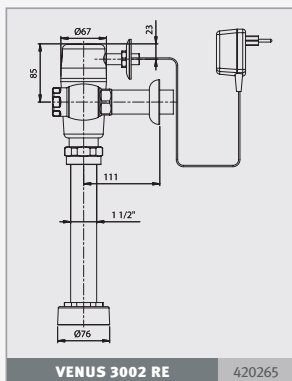
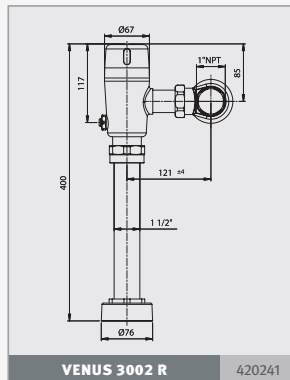
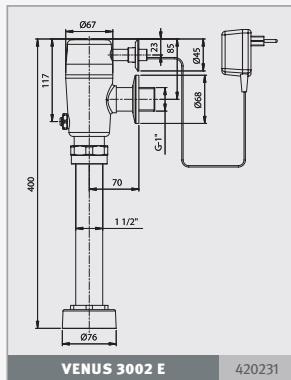
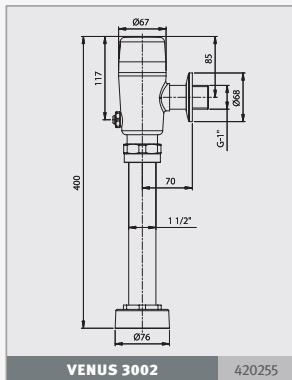

PACK CONTENTS

VENUS 3002 / VENUS 3002R /
JUPITER 3002 / JUPITER 3002R

Familiarize yourself with the part names and confirm that the parts are included.

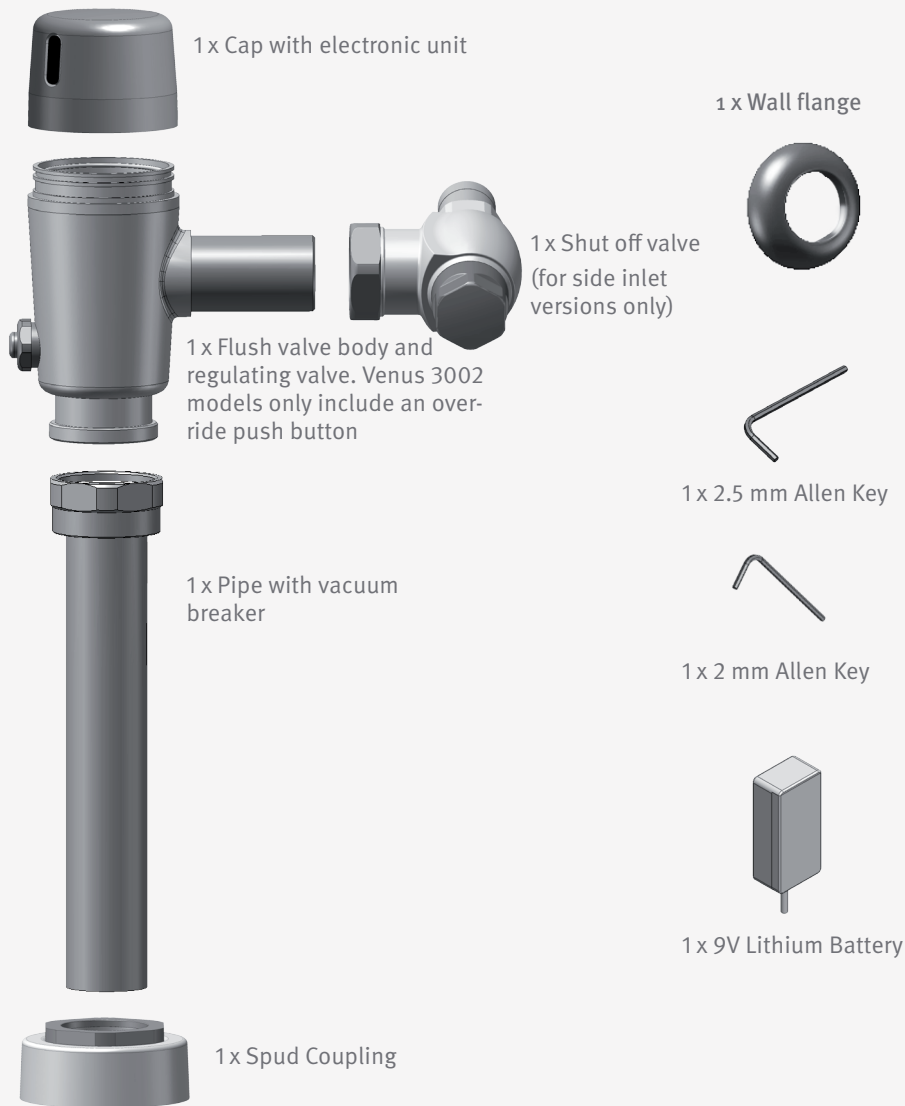

PACK CONTENTS

VENUS 3002E / VENUS 3002RE /
JUPITER 3002E / JUPITER 3002RE

Familiarize yourself with the part names and confirm that the parts are included.

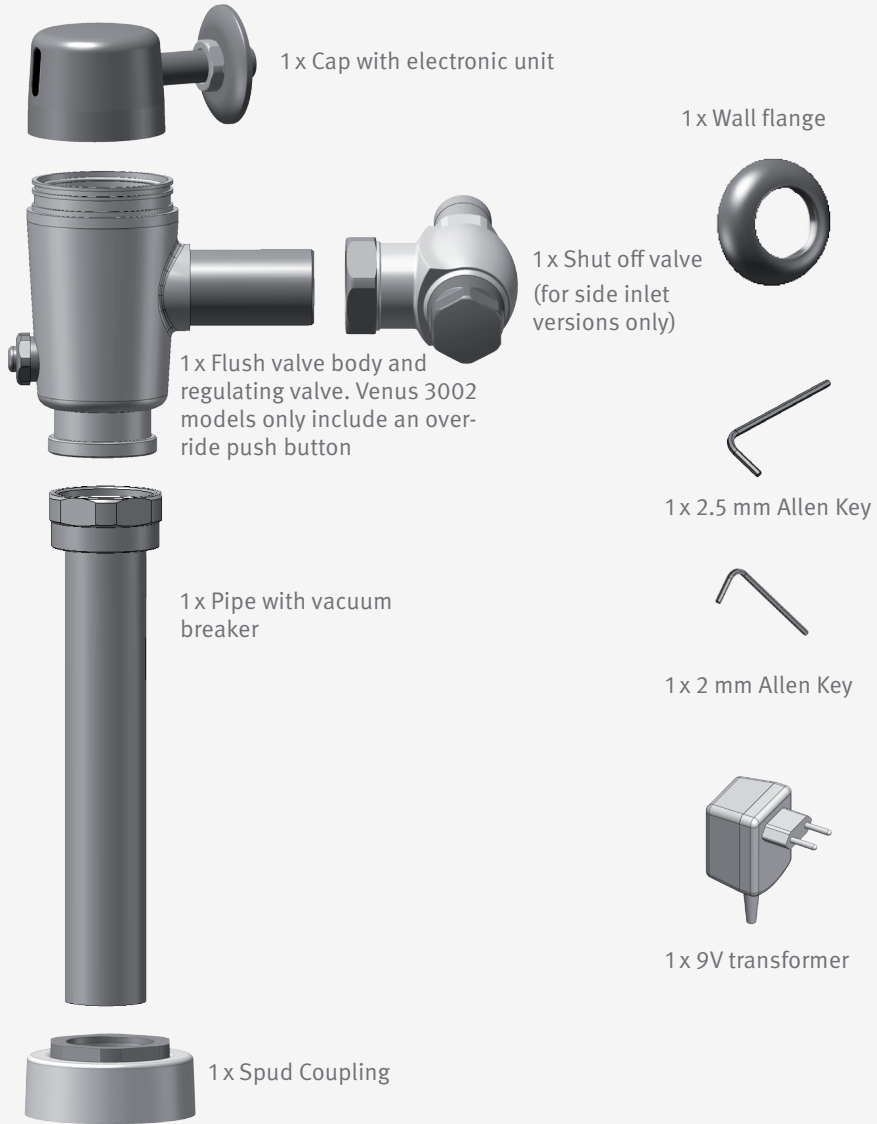

PRE-INSTALLATION INFO

CHECK CONTENTS

Separate all parts from the packaging and check each part with the “Pack contents” section.

Pay attention to the different models variations.

Make sure all parts are accounted for before discarding any packaging material.

If any parts are missing, do not attempt to install your electronic faucet until you obtain the missing parts.

WARNINGS

Do not install facing a mirror or any other electronic system operated by an infrared sensor.

To prevent reflection problems, it is recommended to keep a minimum distance of 1.50 meters between the faucet and any other objects.

NOTE: Keep a minimum distance of 500mm between the upper surface of the bowl and the infra red sensor.

PREPARATION FOR INSTALLATION

Flush water supply lines thoroughly before installing the faucet. Do not allow dirt, Teflon tape or metal particles to enter the faucet.

Shut off water supply.

IMPORTANT

All plumbing is to be installed in accordance with applicable codes and regulations.

INSTALLATION

1

Shut off the water supply.

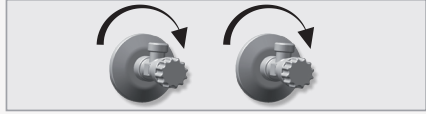

FOR JUPITER R/RE, VENUS R/RE MODELS

Connect the water supply pipe to the water supply and slide the wall flange on it.

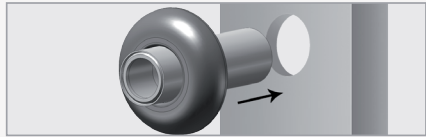

Assemble the shut off valve to the water supply pipe.

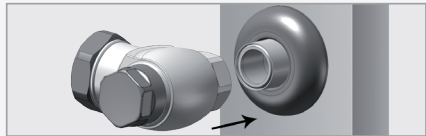

Assemble the valve body to the shut off valve.

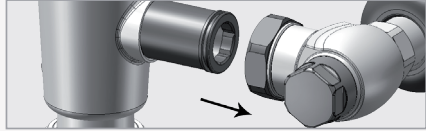

2

FOR JUPITER /E, VENUS/E MODELS

Slide the wall flange on the valve body.

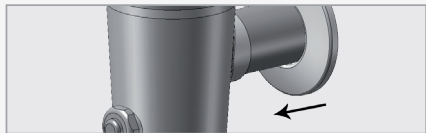

Assemble the valve body to the water supply pipe.

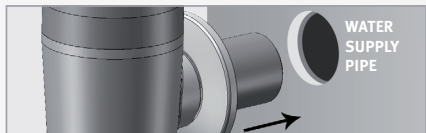

Slide the wall flange until it rests against the finished wall.

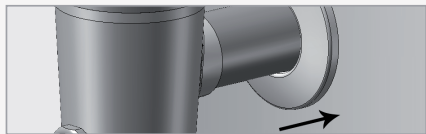

INSTALLATION

3

Slide the spud coupling nut over the vacuum breaker pipe, do not tighten the vacuum breaker coupling nut yet.

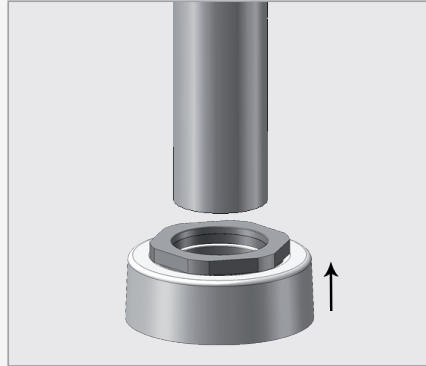

4

Insert the vacuum breaker pipe into the toilet or urinal inlet.

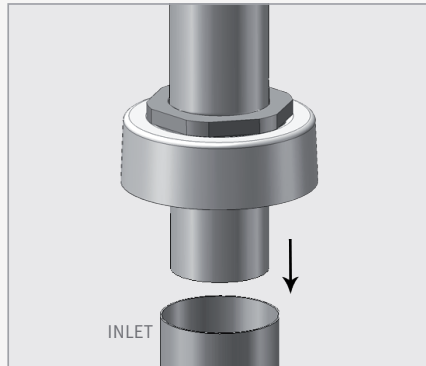

5

Connect the vacuum breaker pipe to the flush valve body by tightening the nut. Make sure the friction ring is placed between the flush valve body and the vacuum breaker pipe.

Align the flush valve body on top of the vacuum breaker pipe and securely tighten the tailpiece coupling, the vacuum breaker coupling and the spud coupling respectively.

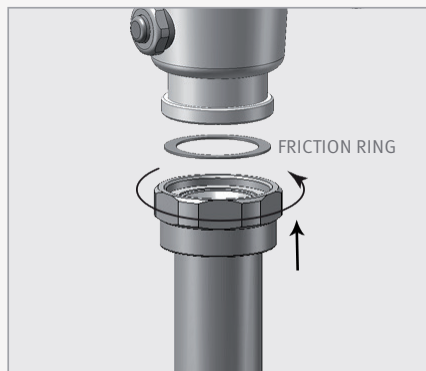

INSTALLATION

For battery operated versions:

Connect the battery to the electronic unit connector and place the battery inside the flush valve cap.

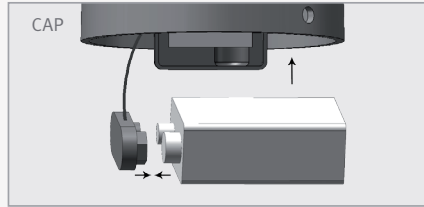

For transformer operated versions:

6

a) Pass the electric wires through the cable compartment located in the flush valve cap.

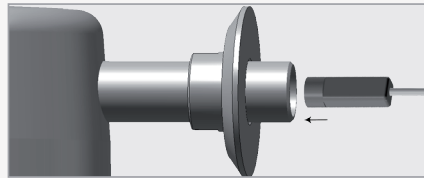

b) Connect the electronic unit and transformer connectors. Make sure that the connectors are then located inside the cap.

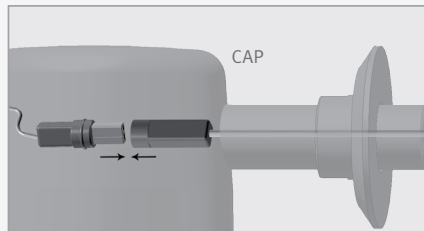

c) Plug the transformer to the main electricity supply.

7

Connect the electronic unit and solenoid valve connectors and remove the sticker.

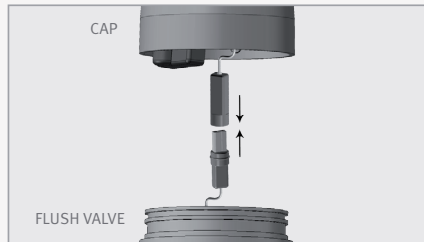

8

Assemble the cap on the flush valve body, making sure that the o-rings are located in between and tighten the screws.

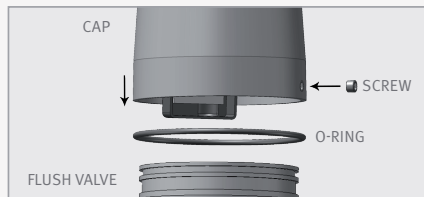

MANUAL RANGE ADJUSTMENT

The sensor range is the range an object can be away from the sensor in order to activate the flush valve. The sensor is factory preset. If necessary, it can be adjusted as follows:

Adjusting the sensor range manually:

1. Disconnect the battery from the sensor.
2. Make a short circuit between the (+) and the (-) of the sensor. You can use a screw driver or another conductor material to make this short circuit. Alternatively, after disconnecting the power supply, activate the sensor three or four times.

Do not make a short circuit on the power supply or on the sensor when the power supply is connected to the sensor.

3. Reconnect the power supply to the sensor.
4. To enter into the adjusting mode, put your hand in front of the sensor at a distance of 2 “(5cm) to 4”(10cm) within 5 seconds after the reconnection of the power supply.

NOTE: If you will not put your hand in front of the sensor after connecting the power supply, the sensor will not enter into adjusting mode and the previous setting will return.

5. When the sensor enters into adjusting mode and your hand is in front of the sensor, a slow flashing of the red light at the front of the sensor will occur.
6. Keep your hand in front of the sensor until the slow flashing changes into quick flashing. At this point move your hand to the required distance from the sensor and wait until the red light will stop flashing.
7. When the red light has turned off, your sensor has been adjusted to the required distance.
8. Check the distance you have set and if it is not satisfactory, repeat steps 1-6.

SETTINGS ADJUSTMENT

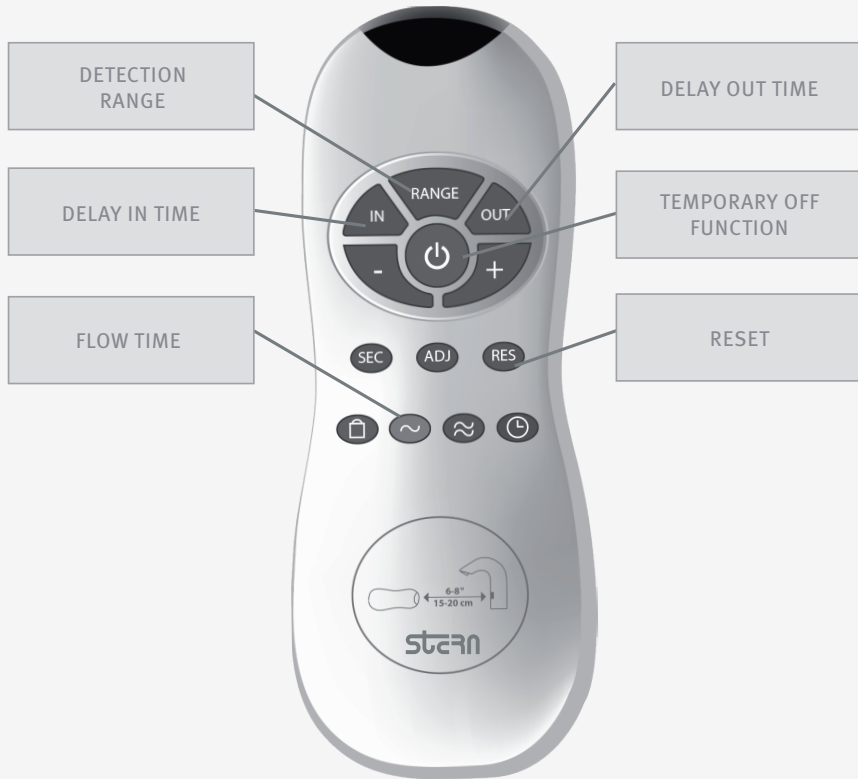

ADJUSTING THE SETTINGS WITH THE REMOTE CONTROL

If necessary, the sensor settings can be adjusted as following:

Shut off the water supply. In order to adjust the sensor with the remote control, hold the remote control straight in front of the sensor in a distance of about 6-8" (15-20cm). Choose the function you want to adjust by pressing once on one of the function buttons. After pressing once on a specific function button, a quick flashing of the red light at the front of the sensor will occur. At this stage, you can change the setting by pressing the (+) or the (-) buttons, every push will increase or decrease one level. After finishing the adjustment, turn the water supply back on.

SETTINGS ADJUSTMENT



DETECTION RANGE: The sensor range is the greatest distance that an object can be away from the sensor to activate the flush valve. The sensor is factory preset.

To adjust the sensor range, press the RANGE button. Wait until a quick flashing of the red light of the sensor eye is perceived. Then, press + to increase the one level and – to reduce it every push will increase or decrease one level.



FLOW TIME: Changes the flush valve flush time, once the user leaves the urinal or the toilet. Press + to increase the flow time and – to decrease it.



DELAY IN TIME: It is recommended to change the delay in time for flush valves for urinals or toilets only.

If required, the delay in time can also be modified in faucets as follows: Press the IN button. Wait until a quick flashing of the red light of the sensor eye is perceived. Then, press + to increase the delay in time and – to reduce it.



DELAY OUT TIME: This button allows modifying the water flow time after the user removes his hands from the flush valve. A delay out time close to 0 (zero) will save more water. An increased delay out time will make the user experience more comfortable.

If required, the delay out time can be modified as follows: Press the OUT button. Wait until a quick flashing of the red light of the sensor eye is perceived. Then, press + to increase the delay out time and – to reduce it.



TEMPORARY OFF FUNCTION: This function is ideal to perform any kind of activity in front of the sensor without operating the system (for example, cleaning).

The flush valve will remain shut for 1 minute when this button is pressed once. To cancel this function and to return to normal operation press the On/Off button again or wait 1 minute.



RESET BUTTON: This function restores all the factory settings except for the sensor range. If required, press the Reset button and without releasing it, press the + button once.

BATTERY REPLACEMENT

When the battery weakens, the red indicator light will blink at a constant rate. The battery must be replaced within two weeks.

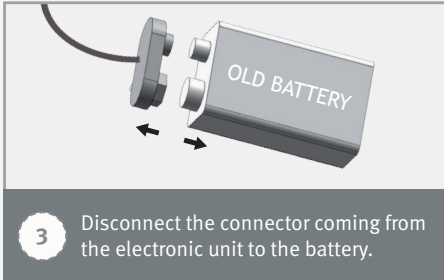
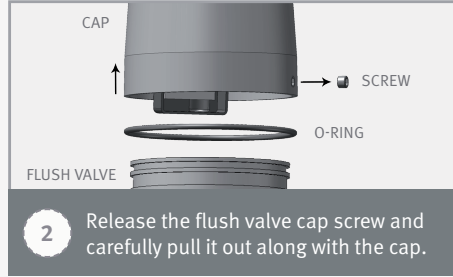
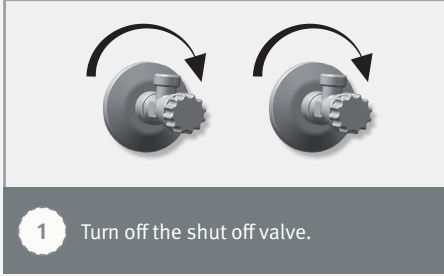

NOTE: BEFORE REASSEMBLING THE ELECTRONIC CAP, MAKE SURE THAT THE EXTERNAL O-RING IS NOT DAMAGED. REPLACE IT IF NECESSARY.

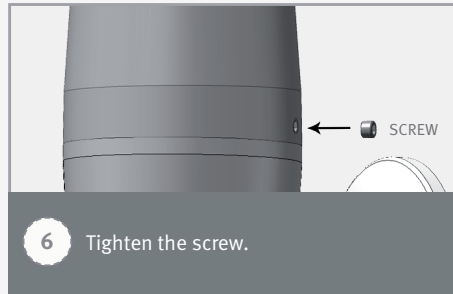
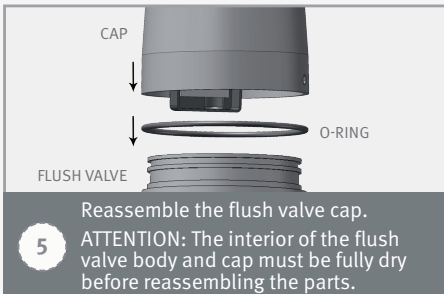

IMPORTANT: Spent batteries should not be disposed of with normal household waste. Contact your local authority for information on waste disposal and recycling.

SPARE PARTS LIST

VENUS SERIES	
Seals and Screws kit	07210045
Sensor kit for Venus 3002 / Venus 3002R	07220200
Sensor kit for Venus 3002E / Venus 3002RE	07220201
Cover kit for Venus 3002 / Venus 3002R	07270030
Cover kit for Venus 3002E	07270016
Cover kit for Venus 3002RE	07270113
Solenoid valve kit with Acetal body	07230015
Piston Kit	07290039
Piston+Piston Cover Kit	07290053
Vacuum Breaker Kit	07291001
1-1/2" Tail Piece Kit	07291003
Push Button Kit	07245018
1" Stop Valve Kit (Venus 3002R / Venus 3002RE)	07291004
Transformer (EU Plug)	06522091

SPARE PARTS LIST

JUPITER SERIES	
Seals and Screws kit	07210045
Sensor kit for Jupiter 3002 / Jupiter 3002R	07220211
Sensor kit for Jupiter 3002E / Jupiter 3002RE	07220212
Cover kit for Jupiter 3002 / Jupiter 3002R	07270030
Cover kit for Jupiter 3002E	07270016
Cover kit for Jupiter 3002RE	07270113
Solenoid valve kit with Acetal body	07230015
Piston Kit	07290051
Piston+Piston Cover Kit	07290052
Vacuum Breaker Kit	07291001
3/4" TAIL PIECE KIT	07291002
3/4" Stop Valve Kit (Jupiter 3002R / Jupiter 3002RE)	07292001
Transformer (EU Plug)	06522091

WARANTY

Y. Stern Engineering Ltd. warrants that its electronic faucets, flush valves and controls will be free of defects in material and workmanship during normal use for two years from the date the product is purchased.

If a defect is found in normal use, Y. Stern Engineering Ltd. will, at its discretion, repair, provide a replacement part or product, or make appropriate adjustments. Damage caused by accident, misuse, or abuse is not covered by this warranty. Improper care and cleaning will void the warranty. Proof of purchase (original sales receipt) must be provided to Stern Engineering Ltd. with all warranty claims.

Stern Engineering Ltd is not responsible for labor charges, installation, or other incidental or consequential costs other than those noted above. In no event shall the liability of Stern Engineering Ltd. exceed the purchase price of the faucet, valve or control.

If you believe that you have a warranty claim, contact your Stern Distributor, Dealer or Plumbing Contractor. Please be sure to provide all pertinent information regarding your claim, including a complete description of the problem, the product, model number, the date the product was purchased, from whom the product was purchased and the installation date. Also include your original invoice.

Y. STERN ENGINEERING AND/OR SELLER DISCLAIM ANY LIABILITY FOR SPECIAL, INCIDENTAL OR CONSEQUENTIAL DAMAGES. This warranty excludes product damage due to installation error, incorrect maintenance, wear and tear, battery, water composition, product abuse, or product misuse, whether performed by a contractor, service company, or the consumer. This warranty does not cover product damage caused by the following:

- Incorrect installation, inversions of supply pipes.
- Pressures or temperatures exceeding recommended limits.
- Improper manipulation, tampering, bad or lapsed maintenance.
- Foreign bodies, dirt or scale introduced by the water supply.

MAINTENANCE

Care and cleaning of chrome and special finishes

DO NOT use steel wool or cleansing agents containing alcohol, acid, abrasives, or the like. Use of any prohibited cleaning or maintenance products or substances could damage the surface of the flush valve. For surface cleaning use ONLY soap and water, then wipe dry with clean cloth or towel. When cleaning bathroom tile, the flush valve should be protected from any splattering of harsh cleansers.

If system chemical disinfection is practiced, chlorine can be used (calculated chlorine concentration of 50mg/l maximum in water per one hour dwell time) at service interval frequency.

SERVICE CHECK LIST

PROBLEM	INDICATOR	CAUSE	SOLUTION
Valve does not flush	1. The red LED indicator in the sensor flashes continuously when the user steps within the sensor's range.	Low battery.	Replace battery
	2. The red LED indicator in the sensor does not flash (once) when the user steps within the sensor's range.	1. Inappropriate sensor range.	Increase or decrease the sensor range.
		2. Battery is completely used up.	Replace battery.
3. The red LED indicator in the sensor flashes (once) when the user steps within the sensor's range.	3. The sensor is picking up reflections from a mirror or another object.		Eliminate cause of reflections.
	2. Debris or dirt in the solenoid valve clog up the bleeding hole.	Replace or clean the solenoid valve. Unscrew the solenoid, pull out the plunger and the spring from the solenoid and clean them. When placing the plunger and spring back, please make sure the spring is in vertical position.	
3. The water supply pressure is higher than 8 bars or pressure peaks over 8 bars in the water supply causes pressure to be trapped in the flush valve.	Reduce the supply water pressure.		
Continuous Flow	The red LED indicator in the sensor flashes (once) when the user steps within the sensor's range.	1. Debris or dirt in the Flush Valve clog up the piston or the orifice. The piston doesn't close.	Open the piston cover and clean the piston, the orifice and body internally.
		2. Debris or dirt in the solenoid valve. The solenoid valve doesn't close.	Replace or clean the solenoid valve. Unscrew the solenoid, pull out the plunger and the spring from the solenoid and clean them. When placing the plunger and spring back, please make sure the spring is in vertical position.
Water flow diminished		Filter or aerator is clogged	Remove, clean, re-install

SERVICE CHECK LIST

PROBLEM	CAUSE	SOLUTION
Low Discharge	1. The self cleaning needle came out of the piston orifice or is displaced. The orifice delivers more water than usual pushing down the piston, causing the piston to close faster than normal.	Replace the piston.
	2. The U-seal is torn or damaged and doesn't seal well enough.	Replace the U-seal.
	3. Flow time setting is too short..	Increase the flow time.
High Discharge	1. Debris or dirt in the Flush Valve clog up the piston. Friction in the piston movement causes the piston to close slower than normal.	Open the piston cover and clean the piston and body internally.
	2. Dirt in the piston orifice prevents enough water from going through the orifice. The reduced flow causes the piston to close slower than normal.	Open the piston cover and clean the piston and the orifice.
	3. Flow time setting is too long.	Reduce the flow time setting.
Dripping	Debris or dirt in the piston seat.	Clean the piston seat.
	Piston seal is torn or damaged.	Replace piston seal.
	Debris or dirt in the solenoid valve orifice. The solenoid valve doesn't close properly.	Replace or clean the solenoid valve.
	The plunger seal is torn or damaged.	Unscrew the solenoid, pull out the plunger and the spring from the solenoid and clean them. When placing the plunger and spring back, please make sure the spring is in vertical position.

* "Security Mode": If the sensor is covered for more than 90 sec. the faucet will automatically shut off water flow. To return to normal operation remove any blockage.

** In this case, the water flow will stop anyway after 90 seconds because of the security time.

STERN

STERN ENGINEERING LTD.

15 Gan Rave Blvd., 81222 Gan Rave, Yavne, Israel
Tel: 972-8-9326000, Fax: 972-8-9326025, export@sternfaucets.com
www.sternfaucets.com

